

CUSTOM INTEGRAL HAT BRAKE ROTORS

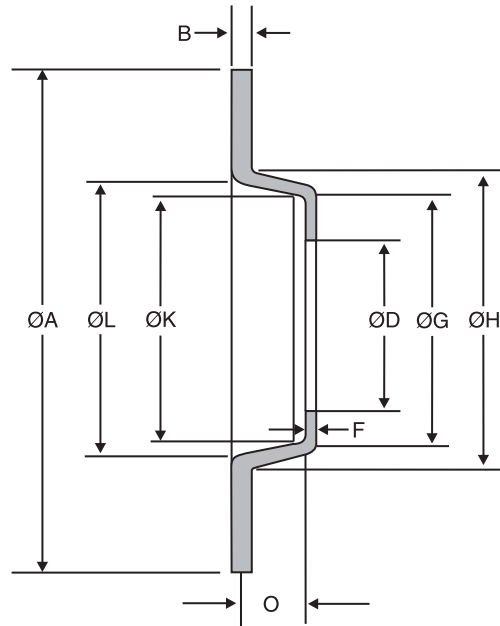
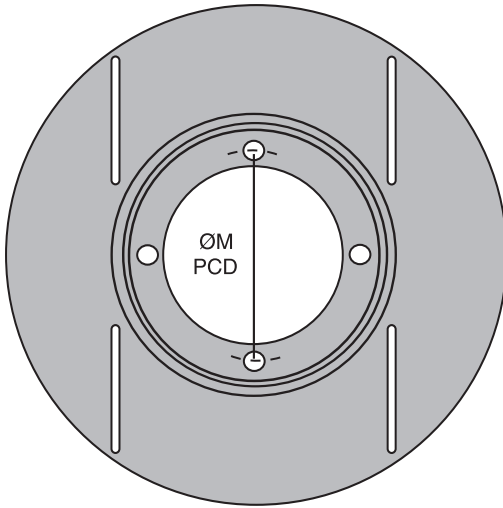

CUSTOM INTEGRAL HAT BRAKE ROTOR CASTING LIMITATIONS

	Maximum	Minimum		Maximum	Minimum
A	12.125	9 1/2 Approx.	L	—	—
B	.500	.250	O	2.700	N/A
D	N/A	2.250	M	Specify no. of holes, size & bolt circle	
F	Specify	Specify	CD	-Cross Drilled	
G	7.00	Specify	W	-With Gas Slots	
H	—	—	WO	-Without Gas Slots	
K	6.500	Specify			

Customer Name: _____

Telephone: _____

Fax: _____

Customer Address: _____

Ship To: _____

Chassis Type-Class of Vehicle: _____

Special Requirements/Notes: _____

A _____

B _____

D _____

F _____

G _____

H _____

K _____

L _____

O _____

M Number of holes: _____

Size: _____

Bolt Circle: _____

CD **W** **WO**

CUSTOM BRAKE ROTORS

The range includes diameters from 9" to 16" and various thickness from 3/8" to 1 1/2".

Available to suit all mounting applications.

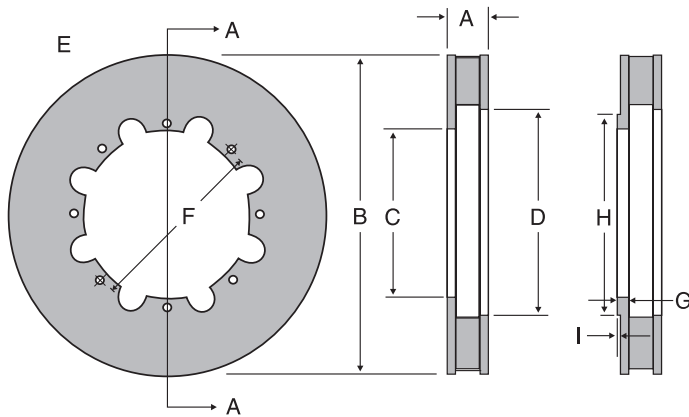

CUSTOM BRAKE ROTOR HATS

Made to your specifications from billet aluminum

Please send sample hat, blueprint or sketch for quote.

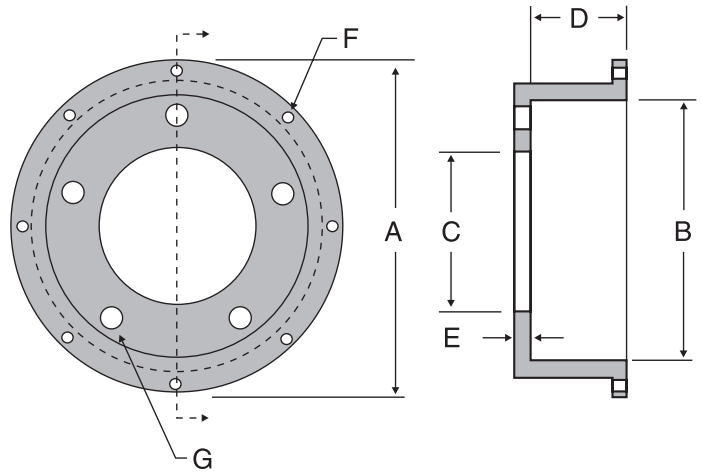

SIZES NEEDED FOR CUSTOM ROTORS

A=Thickness: _____

B=Outside Diameter: _____

C=Flange Diameter: _____

D=Eye Diameter: _____

E= Size of Holes: _____

Number of Holes: _____

F= Bolt Circle: _____

Customer Name: _____

Telephone: _____

Fax: _____

Customer Address: _____

Ship To: _____

Chassis Type-Class of Vehicle: _____

SIZES NEEDED FOR CUSTOM HATS

A=Maximum diameter for caliper clearance: _____

B=Minimum diameter to fit over hub: _____

C=Center bore diameter: _____

D=Actual offset: _____

E=Face thickness: _____

F=Number of holes: _____

hole size: _____

bolt circle rotor mount: _____

G=Number of holes: _____

hole size: _____

bolt circle stud pattern: _____

Special Requirements/Notes: _____
